



Diaphragm seal MD 80 Flange version



Benefits

- Flush, welded diaphragm
- For DIN and ASME flange connections
- Numerous special materials and coatings (option)
- With bottom instrument connection as cell design (option)

Application

For mounting to Bourdon tube pressure gauges, pressure transducers or pressure switches. For corrosive, highly viscous, polluted, crystallising or hot media. Typical application areas:

- Chemical Industry
- Petrochemistry
- Refineries
- Power plant engineering

Versions

flange connection as per ASME B 16.5 (Raised Face)

	Process connection	Instrument connection	Nominal pressure	Minimum range* (in bar) at nominal size				Part no.
				63	100	160	DMU	
	1"	Welded connection	CL 150	4 bar	4 bar	–	1 bar	31393W
	1"	Welded connection	CL 300	4 bar	4 bar	–	1 bar	31394W
	1½"	Welded connection	CL 150	4 bar	4 bar	4 bar	1 bar	31396W
	1½"	Welded connection	CL 300	4 bar	4 bar	4 bar	1 bar	31397W
	2"	Welded connection	CL 150	0.6 bar	0.6 bar	0.6 bar	0.6 bar	31399W
	2"	Welded connection	CL 300	0.6 bar	0.6 bar	0.6 bar	0.6 bar	31400W
	3"	Welded connection	CL 150	0.6 bar	0.6 bar	0.6 bar	0.6 bar	31402W

Blue part no. = in-stock items



Process connection	Instrument connection	Nominal pressure	Minimum range* (in bar) at nominal size				Part no.
			63	100	160	DMU	
3"	Welded connection	CL 300	0.6 bar	0.6 bar	0.6 bar	0.6 bar	31403W
4"	Welded connection	CL 150	0.6 bar	0.6 bar	0.6 bar	0.6 bar	31405W
4"	Welded connection	CL 300	0.6 bar	0.6 bar	0.6 bar	0.6 bar	31406W

Blue part no. = in-stock items

flange connection as per EN 1092-1 type B 1

Process connection	Instrument connection	Nominal pressure	Minimum range* (in bar) at nominal size				Part no.
			63	100	160	DMU	
DN 25	Welded connection	PN 40	4 bar	4 bar	–	0.6 bar	31333W
DN 40	Welded connection	PN 40	4 bar	4 bar	–	0.6 bar	31336W
 DN 50	Welded connection	PN 40	0.6 bar	0.6 bar	0.6 bar	0.6 bar	31339W
DN 80	Welded connection	PN 40	0.6 bar	0.6 bar	0.6 bar	0.6 bar	31385W
DN 100	Welded connection	PN 40	0.6 bar	0.6 bar	0.6 bar	0.6 bar	31388W

Blue part no. = in-stock items

Technical specifications

Process connection/tubus

Stainless steel 316 L

Flange connection as per ASME B 16.5 (Raised Face) or as per EN 1092-1 type B 1

Diaphragm

Stainless steel 316 L

Instrument connection

Welded connection

Pressure transmission liquid

Paraffin oil (FM 09), FDA-listed

Pressure range

See overview of versions

Nominal pressure

CL 150, CL 300, PN 40

Options

Process connection

- Special materials/coatings
- Other sealing surfaces
- Cell design

Diaphragm

- Special materials: Hastelloy, Monel, nickel, Inconel, Incoloy, platinum, titanium, tantalum, zirconium, other chrome-nickel-steel alloys
- Coatings/linings: PFA (up to 250 °C), ECTFE (up to 150 °C), PTFE (up to 150 °C, up to 100 bar), silver (up to 150 °C), gold (up to 200 °C)

Other

- Higher nominal pressures
- Adapter for instrument connection G¹/₄B/G¹/₂B
- Cooling element (> 100 °C)
- Capillary tube (back or bottom)
- Other filling liquids
- Customer-specific flanges
- Other nominal diameters



Technical drawings

Type MD 80 - flange connection as per ASME B 16.5 (Raised Face)

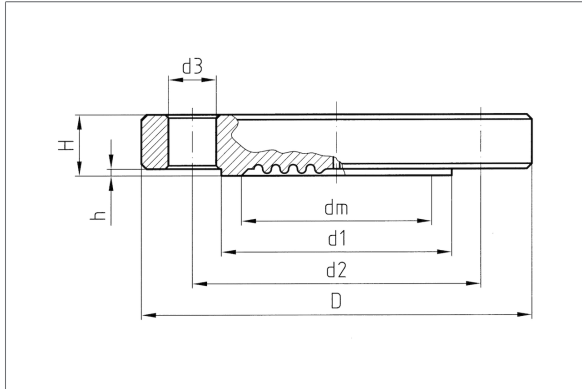

DN	CL	D	d1	d2	d3	H	h	dm
1"	150	108	50,8	79,4	4x15,9	14,3	1,6	28
	300	123,9	50,8	88,9	4x19,1	17,5	1,6	28
1½"	150	127	73,2	98,6	4x15,9	17,5	1,6	36
	300	155,6	73,2	114,3	4x22,4	22,4	1,6	36
2"	150	152,4	92,1	120,7	4x19,1	19,1	1,6	48
	300	165,1	92,1	127	8x19,1	25,4	1,6	48
3"	150	190,5	127	152,4	4x19,1	23,9	1,6	48
	300	209,6	127	168,3	8x22,4	31,8	1,6	48
4"	150	228,6	157,2	190,5	8x19,1	23,9	1,6	48
	300	254	157,2	200,1	8x22,3	31,7	1,6	48

DN	PN	D	d1	d2	d3	H	h	dm
25	40	115	68	85	4x14	18	2	28
40	40	150	88	110	4x18	18	2	48
50	40	165	102	125	4x18	18	2	48
80	40	200	138	160	8x18	24	2	48
100	40	235	162	190	8x22	24	2	48

Adapter for instrument connection G¼/G½ with filling port

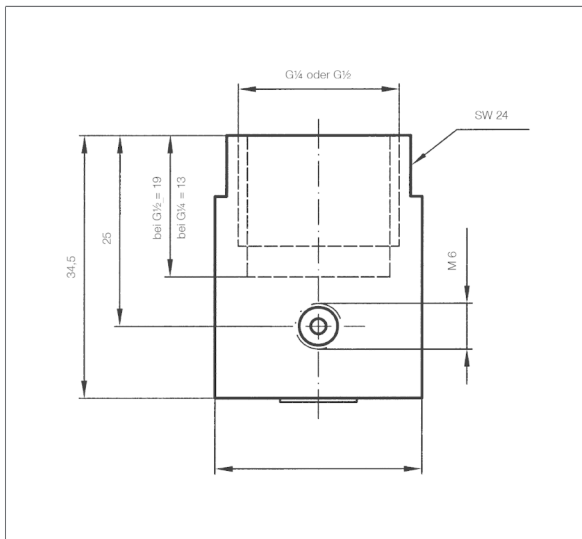

Cooling element, can be welded at both ends

